

ME 425 AC
ME 430 AC

2500 3000

2006



 **MANITOU**

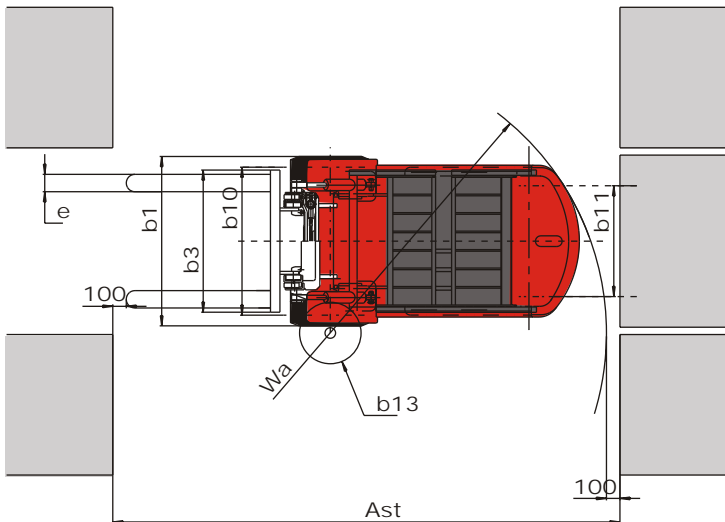
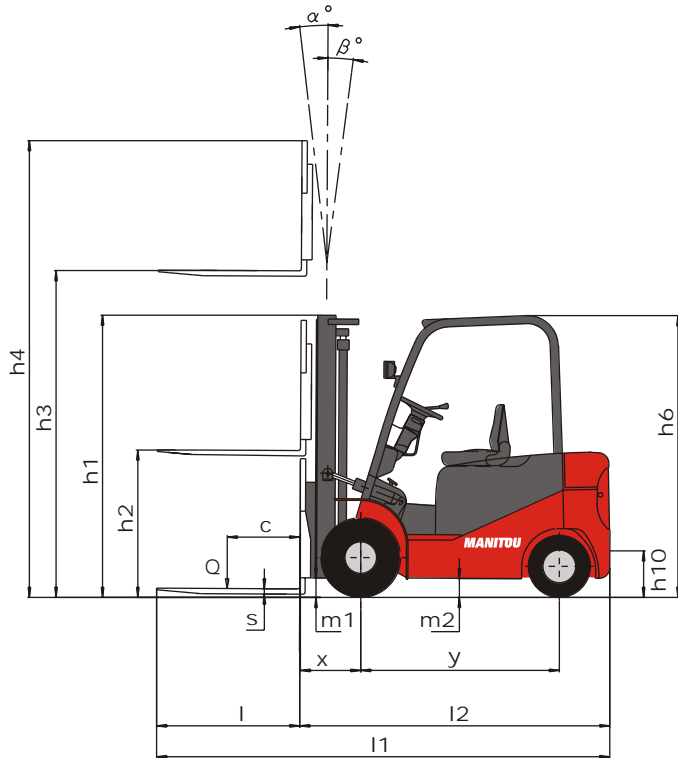

1.1	
1.2	
1.3	
1.4	
1.5	
1.6	
1.8	
1.9	
2.1	
2.2	
2.2.1	
2.3	
2.3.1	
3.1	
3.2	
3.3	
3.5	
3.5.1	
3.6	
3.7	
4.1	
4.1.1	
4.2	
4.3	
4.4	
4.5	
4.7	
4.12	
4.19	
4.20	
4.21	
4.22	
4.22.1	
4.22.2	
4.23	
4.24	
4.31	
4.32	
4.33	1000 1200
4.34	800 1200
4.35	
4.36	
5.1	
5.1.1	
5.2	
5.2.1	
5.3	
5.3.1	
5.5	
5.5.1	
5.7	
5.7.1	
5.9	
5.9.1	
5.10	
6.1	,
6.2	, 20%
6.4	
8.1	
8.2	
8.3	

	MANITOU	MANITOU
	ME 425	ME 430
(/A)		
Q ()	2,5	3
c ()	500	500
x ()	455	475
y ()	1485	1625
	4285	5400
	-	-
	-	-
	-	-
	-	-
	SE	SE
"	23x9 - 10	23x9 - 10
"	18x7 - 8	18x7 - 8
	2x	2x
	2	2
b10 ()	1058	1058
b11 ()	960	960
? (°)	5	5
? (°)	10	10
h1 ()	2186	2186
h2 ()	140	145
h3 ()	3300	3300
h4 ()	4356	4452
h6 ()	2165	2165
h10 ()	250	255
l1 ()	3395	3560
l2 ()	2325	2490
b1 ()	1265	1260
s ()	40	45
e ()	130	130
l ()	1070	1070
	FEM 2A	FEM 3A
b3 ()	1060	1060
m1 ()	98	102
m2 ()	120	125
Ast ()	3911	4071
Ast ()	4010	4170
Wa ()	2090	2230
b13 ()	45	45
/	14	14
/	14	14
/	0,24	0,25
/	0,24	0,4
/	0,44	-
/	0,36	-
	-	-
	-	-
%	51	13
%	52	14
	-	-
	-	-
	10,5	10,6
	11	12,8
/A	48 / 700	80 / 560
	175	175
/	65	65

2,5 T								500
	mm	H2						2,5 T
			H1	H4	H4			
	3300	140	2186	4356	-	5°	10°	2500
	3600	140	2336	4656	-	5°	10°	2500
	4000	140	2586	5056	-	5°	10°	2500
	3300	1465	2150	4356	3985	5°	10°	2500
	4500	1387	2096	5556	5219	5°	6°	2230
	5000	1552	2261	6056	5719	5°	6°	1860
	5500	1717	2426	6556	6219	3°	6°	1430
	6000	1932	2641	7056	6719	3°	6°	1220

3 T								500
		H2						3
			1	4	H4			
	3300	145	2186	4452	-	5°	10°	3000
	3600	145	2336	4752	-	5°	10°	3000
	4000	145	2586	5152	-	5°	10°	3000
	3300	1449	2186	4452	4047	5°	10°	3000
	4500	1348	2121	5652	5283	5°	6°	2720
	5000	1514	2287	6152	5783	5°	6°	2160
	5500	1678	2451	6652	6283	3°	6°	1850
	6000	1844	2617	7152	6783	3°	6°	1680

